

AXL F RS UNI 1H

**Axioline F XC, communication module,
interface: RS-232, RS-485, RS-422**

Data sheet
8533_en_06

© PHOENIX CONTACT 2020-10-06



1 Description

The module is designed for use within an Axioline F station. The module is used to operate standard I/O devices with serial interfaces on a bus system.

Features

- A serial input and output channel in RS-232, RS-422, and RS-485 format
- Various protocols supported
- Transmission speed can be set up to 250,000 baud
- Parameterization via the PDI channel
- Device rating plate stored



This data sheet is only valid in association with the UM EN AXL F SYS INST user manual.



Make sure you always use the latest documentation.
It can be downloaded at: phoenixcontact.net/product/2688666

2	Table of contents	
1	Description	1
2	Table of contents	2
3	Ordering data	3
4	Technical data	4
5	Internal circuit diagram	7
6	For your safety	7
7	Terminal point assignment.....	8
8	Connection notes	9
9	Connection examples	9
10	Local diagnostic and status indicators	11
11	Serial interfaces	13
12	Mass storage and transmission	14
13	Process data.....	16
14	Process data word 0	17
15	Commands	19
16	Parameter, diagnostics and information (PDI)	22
17	Standard objects	23
18	Application objects	27
19	Device descriptions	31

3 Ordering data

Description	Type	Order No.	Pcs./Pkt.
Axioline F, Communication module, interface: RS-232, RS-485, RS-422, transmission speed in the local bus: 100 Mbps, degree of protection: IP20, including bus base module and Axioline F connectors	AXL F RS UNI 1H	2688666	1
Accessories	Type	Order No.	Pcs./Pkt.
Axioline F bus base module for housing type H (Replacement item)	AXL F BS H	2700992	5
Zack marker strip for Axioline F (device labeling), in 2 x 20.3 mm pitch, unprinted, 25-section, for individual labeling with B-STIFT 0.8, X-PEN, or CMS-P1-PLOTTER (Marking)	ZB 20,3 AXL UNPRINTED	0829579	25
Zack Marker strip, flat, Strip, white, unlabeled, can be labeled with: PLOTMARK, CMS-P1-PLOTTER, mounting type: snap into flat marker groove, for terminal block width: 10.15 mm, lettering field size: 4 of 10.15 x 5 mm and 1 of 5.8 x 5 mm, Number of individual labels: 50 (Marking)	ZBF 10/5,8 AXL UNPRINTED	0829580	50
Axioline shield connection set (contains 2 shield bus holders and 2 SK 5 shield connection clamps)	AXL SHIELD SET	2700518	1
Insert label, Roll, white, unlabeled, can be labeled with: THERMOMARK ROLLMASTER 300/600, THERMOMARK X1.2, THERMOMARK ROLL X1, THERMOMARK ROLL 2.0, THERMOMARK ROLL, mounting type: snapped into marker carrier, lettering field size: 35 x 28 mm, Number of individual labels: 500 (Marking)	EMT (35X28)R	0801602	1
Documentation	Type	Order No.	Pcs./Pkt.
User manual, English, Axioline F: System and installation	UM EN AXL F SYS INST	-	-
User manual, English, Axioline F: Diagnostic registers, and error messages	UM EN AXL F SYS DIAG	-	-

4 Technical data

Dimensions (nominal sizes in mm)

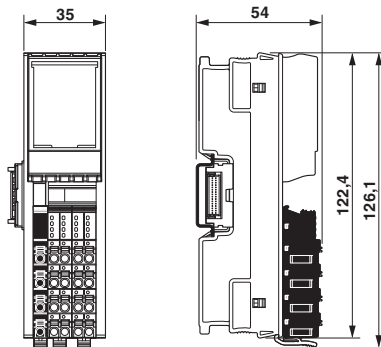

Width	35 mm
Height	126.1 mm
Depth	54 mm
Note on dimensions	The depth is valid when a TH 35-7,5 DIN rail is used (according to EN 60715).

General data

Color	traffic grey A RAL 7042
Weight	135 g (with connectors and bus base module)
Mounting type	DIN rail
Ambient temperature (operation)	-25 °C ... 60 °C
Ambient temperature (storage/transport)	-40 °C ... 85 °C
Permissible humidity (operation)	5 % ... 95 % (non-condensing)
Permissible humidity (storage/transport)	5 % ... 95 % (non-condensing)
Air pressure (operation)	70 kPa ... 106 kPa (up to 3000 m above sea level)
Air pressure (storage/transport)	70 kPa ... 106 kPa (up to 3000 m above sea level)
Degree of protection	IP20
Protection class	III (IEC 61140, EN 61140, VDE 0140-1)
Mounting position	any (no temperature derating)

Connection data: Axioline F connector

Connection method	Push-in connection
Conductor cross section solid / stranded	0.2 mm ² ... 1.5 mm ² / 0.2 mm ² ... 1.5 mm ²
Conductor cross section [AWG]	24 ... 16
Stripping length	8 mm



Please observe the information provided on conductor cross sections in the "Axioline F: system and installation" user manual.

Interface: Axioline F local bus

Number	2
Connection method	Bus base module
Transmission speed	100 Mbps

Interface: RS-232, RS-485, RS-422

Number of interfaces	1
Connection method	Push-in connection
Transmission speed	110 bps ... 250 kbps (can be parameterized)
Transmission physics	Copper
Protocols supported	Transparent, end-to-end, XON/XOFF, Modbus/RTU (master support)
Input buffer	4 kByte
Output buffer	1 kByte
Data bits	5 ... 8
Stop bits	1 or 2
Parity	Even, odd or no parity
Termination resistor	active, integrated

Axioline F local bus supply (U_{Bus})



The I/O is also supplied from the communications power U_{Bus} .
The I/O supply is electrically isolated from the local bus.

Supply voltage	5 V DC (via bus base module)
Current consumption	typ. 200 mA max. 240 mA
Power consumption	typ. 1 W max. 1.2 W

Input and output address area

Input address area	20 Byte
Output address area	20 Byte

Configuration and parameter data in a PROFIBUS system

Required parameter data	14 Byte
Required configuration data	7 Byte

Electrical isolation/isolation of the voltage areas

Test section	Test voltage
5 V supply of the local bus (U_{Bus}) / 5 V supply (I/Os)	1000 V DC, 1 min.
5 V supply of the local bus (U_{Bus}) / functional ground	1000 V DC, 1 min.
5 V supply (I/O)/functional ground	1000 V DC, 1 min.

Mechanical tests

Vibration resistance in acc. with EN 60068-2-6/ IEC 60068-2-6	5g
Shock in acc. with EN 60068-2-27/IEC 60068-2-27	30g
Continuous shock according to EN 60068-2-27/ IEC 60068-2-27	10g

Conformance with EMC Directive 2014/30/EU

Noise immunity test in accordance with EN 61000-6-2

Electrostatic discharge (ESD) EN 61000-4-2/ IEC 61000-4-2	Criterion B, 6 kV contact discharge, 8 kV air discharge
Electromagnetic fields EN 61000-4-3/IEC 61000-4-3	Criterion A, Field intensity: 10 V/m
Fast transients (burst) EN 61000-4-4/IEC 61000-4-4	Criterion B, 2 kV
Transient overvoltage (surge) EN 61000-4-5/ IEC 61000-4-5	Criterion B, DC supply lines: ± 0.5 kV/ ± 0.5 kV (symmetrical/ asymmetrical)
Conducted interference EN 61000-4-6/IEC 61000-4-6	Criterion A, Test voltage 10 V
Noise emission test according to EN 61000-6-3	Class B

Approvals

For the latest approvals, please visit phoenixcontact.net/products.

5 Internal circuit diagram

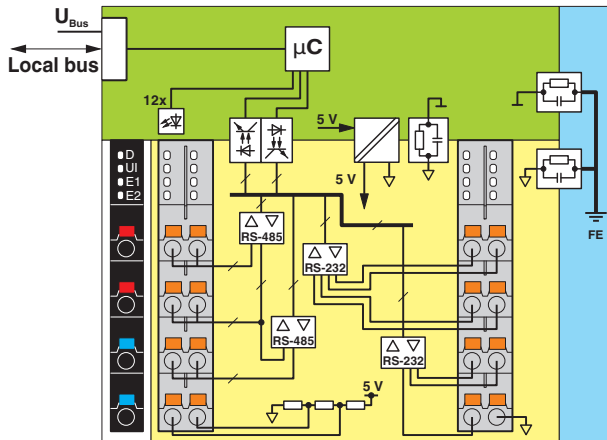

Figure 1 Internal wiring of the terminal points

Key:

Local bus	Axioline F local bus (hereinafter referred to as local bus)
	Microcontroller
	Electrical isolation (optocoupler or isolator)
	Diagnostic and status indicators
	RS-485/422/232 interface
	DC/DC converter with electrical isolation
	Coupling network
	Electrically isolated areas

6 For your safety

6.1 Intended use

Use the Axioline F modules exclusively in accordance with the specifications in the accompanying data sheet and the “Axioline F: System and Installation” user manual.

6.2 Qualification of users

The use of products described in this data sheet is oriented exclusively to electrically skilled persons or persons instructed by them. The users must be familiar with the relevant safety concepts of automation technology as well as applicable standards and other regulations.

6.3 Electrical safety



WARNING: loss of electrical safety

If used incorrectly, device safety may be impaired.

The instructions given in this data sheet as well as the UM EN AXL F SYS INST user manual must be observed during installation, startup, and operation.

7 Terminal point assignment

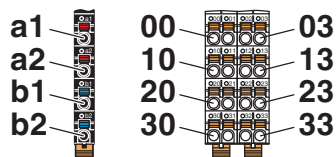

Figure 2 Terminal point assignment

Connector 1		
Terminal point	Color	Assignment
a1, a2	Red	Not used (bridged internally)
b1, b2	Blue	Not used (bridged internally)



You can use connector 1 for potential routing of the 24 V supply voltage. However the voltage is not used by the module.

Connector 2			RS-485	RS-422	Notes
Terminal point	Color	Signal	Description	Description	
00	Orange	TxD+	Not used	Transmit data	positive
10	Orange	RxD+	Transmit/receive data	Receive data	positive
20	Orange	RxD+	Transmit/receive data	Receive data	Positive; for external bridge to 30
30	Orange	R+	Termination resistor	Termination resistor	Positive pole; for external bridge to 20
01	Orange	TxD-	Not used	Transmit data	negative
11	Orange	RxD-	Transmit/receive data	Receive data	negative
21	Orange	RxD-	Transmit/receive data	Receive data	Negative; for external bridge to 31
31	Orange	R-	Termination resistor	Termination resistor	Negative pole; for external bridge to 21

Connector 3: RS-232					
Terminal point	Color	Signal	Description		
02	Orange	RxD	Serial data input		
12	Orange	RTS	Request to send	Request to send; handshake signal; output	
22	Orange	DTR	Data terminal ready	Startup request to the connected device; handshake signal; output	
32	Orange	DCD	Data carrier detect	Connected device ready to operate; handshake signal; input	
03	Orange	TxD	Serial data output		
13	Orange	CTS	Clear to send	Permission to send; connected device ready to receive; handshake signal; input	
23	Orange	DSR	Data set ready	Connected device ready to operate; handshake signal; input	
33	Orange	GND	Ground for the serial interface		

8 Connection notes

- Connect the shield to a busbar before the module.
- Fit the receive signals of the RS-485 or RS-422 network with a termination resistor at the relevant end point.
- If you use the integrated termination resistor, the polarization of the data cable will also be active.

9 Connection examples

Operating mode	Special feature	Notes	Image
RS-485	Module as the network end point	Termination resistor required	9.2
RS-485	Module in the network center		9.3
RS-422	Module is last receiver	Termination resistor required	9.4
RS-232	Four-wire handshake		9.5
RS-232	Without handshake		

9.1 RS-485: module as the network end point

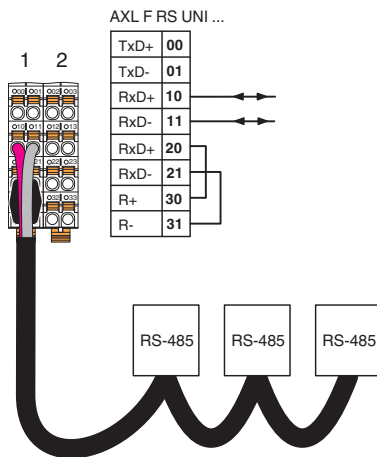

Figure 3 RS-485 interface wiring:
Module as the network end point

9.2 RS-485: module in the network center

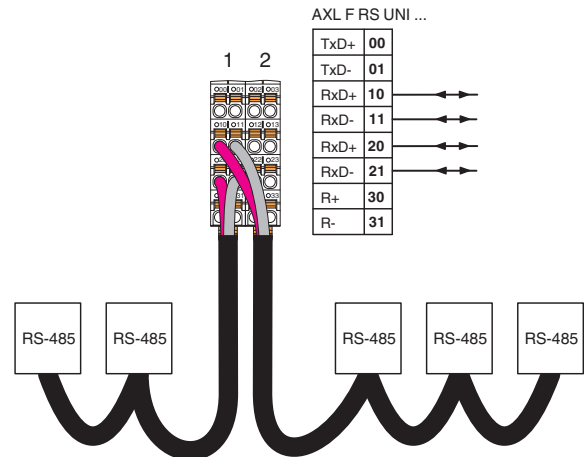

Figure 4 RS-485 interface wiring:
Module in the network center

9.3 RS-422

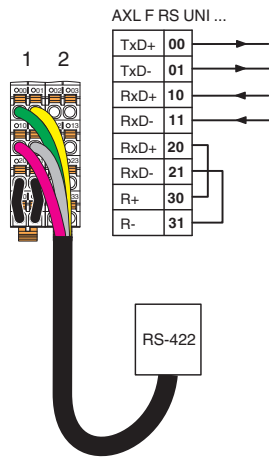

Figure 5 RS-422 interface wiring, full duplex

9.4 RS-232: with 4-wire handshake

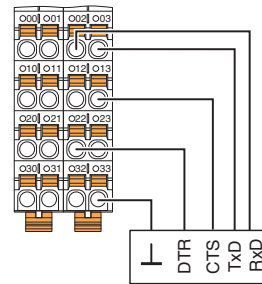

Figure 6 RS-232 interface wiring: four-wire handshake

9.5 RS-232: without handshake

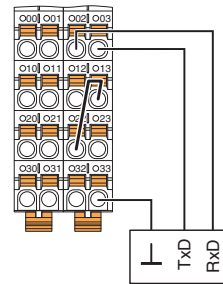
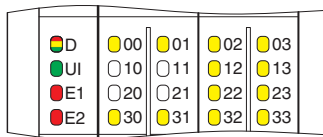

Figure 7 RS-232 interface wiring: without handshake
For wiring without handshake, insert a bridge between terminal points 22 (DTR) and 13 (CTS).

10 Local diagnostic and status indicators



Channel errors are errors that can be associated with a channel.
I/O errors are errors that affect the entire module.

Figure 8 Local diagnostic and status indicators

Connector 1				
Designation	Color	Meaning	State	Description
D	Red/ yellow/ green	Diagnostics of local bus communication		
		Run	Green on	The device is ready for operation, communication within the station is OK. All data is valid. An error has not occurred.
		Active	Green flashing	The device is ready to operate, communication within the station is OK. The data is not valid. The controller or superordinate network is not delivering valid data. There is no error on the module.
		Device application not active	Green/ yellow flashing	The device is ready for operation, communication within the station is OK. Output data cannot be outputted and/or input data cannot be read. There is a fault on the periphery side of the module..
		Ready	Yellow on	The device is ready for operation but did not detect a valid cycle after power-up.
		Connected	Yellow flashing	The device is not (yet) part of the active configuration.
		Reset	Red on	The device is ready for operation but has lost the connection to the bus head.
		Not connected	Red flashing	The device is ready for operation but there is no connection to the previously existing device.
		Power down	Off	Device is in (power) reset.
UI	Green	I/O voltage	On	I/O supply voltage is present (generated from U_{Bus}).
			Off	I/O supply voltage is not present.
E1	Red	I/O error	On	I/O error present.
			Off	No I/O error.
E2	Red	Channel error	On	Channel error present.
			Off	Channel error not present.

Connector 2: RS-485/422				
Designation		Color	State	Description
00	TxD	Yellow	On	Module is transmitting data to the connected device
			Off	Module is not transmitting data
10	-	-	-	Not used
20	-	-	-	Not used
30	RS-485	Yellow	On	Module is parameterized for RS-485
			Off	Module is not parameterized for RS-485
01	RxD	Yellow	On	Module is receiving data from the connected device
			Off	Module is not receiving data
11	-	-	-	Not used
21	-	-	-	Not used
31	RS-422	Yellow	On	Module is parameterized for RS-422
			Off	Module is not parameterized for RS-422

Connector 3: RS-232				
Designation		Color	State	Description
02	RxD	Yellow	On	Module is receiving data from the connected device
			Off	Module is not receiving data
12	RTS	Yellow		Request to send
			On	Handshake signal is set by the module
			Off	Handshake signal is not set
22	DTR	Yellow		Data terminal ready
			On	Handshake signal is set by the module
			Off	Handshake signal is not set
32	DCD	Yellow		Data carrier detect
			On	Handshake signal is set by partner
			Off	Handshake signal is not set
03	TxD	Yellow	On	Module is transmitting data to the connected device
			Off	Module is not transmitting data
13	CTS	Yellow		Clear to send
			On	Handshake signal is set by partner
			Off	Handshake signal is not set
23	DSR	Yellow	On	Data set ready
			On	Handshake signal is set by partner
			Off	Handshake signal is not set
33	RS-232	Yellow	On	Module is parameterized for RS-232
			Off	Module is not parameterized for RS-232

11 Serial interfaces

11.1 RS-232

The RS-232 interface on the terminal represents some form of DTE (data termination equipment).

This means that connector 2 terminal point 2.1 (TxD) is always used to transmit and connector 2 terminal point 1.1 (RxD) is always used to receive.

According to the standard, some form of DCE (data communication equipment) should be connected to the RS-232 interface as a peer. DTE can also be connected.

By measuring the voltage between the terminal points for the TxD and GND signals in the idle state, you can determine whether the device to be connected to the V.24 interface is a form of DTE or DCE. If the voltage measures approximately -5 V, the device is a form of DTE. If the voltage is around 0 V, the device is a form of DCE.

Example: when using a 25-pos. standard connector the voltage between pin 2 (TxD) and pin 7 (GND) must be measured.



In order to obtain the correct results, perform the measurement on the open cable end, i.e., if the modules are not connected together.

RS-232 module handshake signals

Any device with an RS-232 interface can be connected to the RS-232 interface on the module.

Both the module and the device connected to the RS-232 interface can act as a transmitter and a receiver for data exchange.

To avoid errors during data exchange, e.g., a buffer overrun, the handshake is used as a procedure for the mutual signaling of clear to receive and clear to send.

The module supports the RTS, CTS, DTR, DSR, and DCD handshake signals. Each uses one wire of the connecting cable.

The connecting signals are described from the point of view of the module, i.e., from the point of view of the DTE.

11.2 RS-485 (2-wire)

In RS-485 mode, you can create a network with several devices using an existing network consisting of two signal cables.

Use a twisted pair, common shielded data cable to connect the devices. Fit a termination resistor to the data cable at both end points of the RS-485 network. For this, you can use the integrated termination resistor in the module via connections R+ and R-.

If you use the integrated termination resistor, the data cable will also be polarized. This will generate a defined cable idle level.

This operating mode only supports half duplex transmission. Make sure that data is not sent simultaneously by several devices.

11.3 RS-422

In RS-422 operating mode, a point-to-point connection can be established.

Use a twisted pair, common shielded data cable to connect the devices. Fit a termination resistor to this data cable at every device. Use the integrated termination resistor when connecting to the module.

This operating mode supports full duplex transmission.

12 Mass storage and transmission

The module stores the received serial data in an intermediate buffer until it is requested from the serial interface by the bus controller board or the device. Serial data traffic can be managed using various protocols. The protocol used depends on the type of protocol supported by the peer.

12.1 Supported protocols

Protocol	Receive memory	Transmit memory	Special features when receiving
Transparent	4096 bytes	1023 bytes	
End-to-end	3 buffers each with 340 bytes (PD) or 245 bytes (PDI)	1023 bytes (including end characters)	Two end characters are filtered out
XON/XOFF	4096 bytes	1023 bytes	Software handshake
Modbus/RTU	3 buffers each with 340 bytes (PD) or 245 bytes (PDI)	3 buffers each with 340 bytes (PD) or 245 bytes (PDI)	

PD Data exchange via process data

PDI Data exchange via PDI

12.2 Transparent protocol

If the transparent protocol is used, serial data is transmitted in the same format it is received from the serial interface or from the bus side.

The transmit FIFO (first-in, first-out memory) can store 1023 bytes (1 kB) and the receive FIFO can store 4096 bytes (4 kB). If the module receives another character after the 4095th character, the error pattern is stored in the receive FIFO. All other subsequent characters are ignored.

This protocol supports a CTS hardware handshake.

If the available space in the receive memory is less than 15 bytes, DTR is set to logic 0. As soon as more memory space becomes available again, DTR is set to logic 1.

12.3 End-to-end protocol

The serial data is conditioned for the end-to-end protocol. If serial data is sent from the bus side, two additional characters, the first and second delimiters, are attached for transmission to the serial interface.

A block of serial data sent from the serial interface is only valid if the module has received the first and second delimiters. It is only then that the data can be read via the bus side. The delimiters are not forwarded to the higher-level bus with the user data, they are filtered out.

Unlike in the transparent protocol, the receive memory is not organized as a FIFO but as a buffer.

Three buffers are available.

The size of the buffer depends on the parameterized data way:

Data exchange via process data	340 bytes per buffer
Data exchange via PDI	245 bytes per buffer

If the maximum buffer size is exceeded without the two delimiters being detected, the previous characters will be ignored and the buffer will be written again.

The transmit FIFO can store 1023 bytes (1 kbyte). The delimiters are attached to, and stored with, the data to be sent.

12.4 XON/XOFF protocol

This protocol operates in the same way as the transparent protocol, but uses a software handshake.

Data transmission with this protocol is controlled by the XON and XOFF characters. XON is preset to 11_{hex} and XOFF to 13_{hex}.

If the module receives an XOFF, no more serial data will be sent until an XON is received.

The module itself will transmit an XOFF if the available space in the receive memory is less than 15 bytes. As soon as more memory becomes available, the module will transmit a single XON.

Transmission does not depend on the CTS input.

Serial data is not filtered when it is transmitted. Any characters with the code defined for XON or XOFF are therefore transmitted and may trigger undesirable events at the receiver. When serial data is received, the XON and XOFF characters are filtered and are not available to the higher-level system as data. Any characters with the XON or XOFF code are lost. Ensure that characters with these codes do not appear in the regular data stream.

12.5 Modbus/RTU (master support)

Telegram structure

Address	Function	Data	CRC
1 byte	1 byte	0 ... 244 bytes	2 bytes
Data			Automatic generation and check

In the Modbus environment, two time values play an important role: 1.5 characters, also referred to as t1.5 and 3.5 characters, also referred to as t3.5. The times for baud rates above 19,200 baud are set to t1.5 = 1.0 ms and t3.5 = 2.0 ms.

If a break between two characters is greater than t1.5 and less than t3.5, this is identified as a transmission error. The message is considered incomplete and is indicated with a receive error.

If the break after a character is greater than t3.5, this is identified as the telegram end.

Three transmit and three receive buffers are available.

The size of the buffer depends on the parameterized data way:

Data exchange via process data	340 bytes per buffer
Data exchange via PDI	245 bytes per buffer

Modbus/RTU mode offers Modbus/RTU master support. However, the module does not have programmable logic. Modbus/RTU slave support is not implemented.

Data transfer sequence

The two checksum bytes are automatically generated and sent for the user data supplied via the bus (via process data or PDI). Once sent this has been sent, a response is expected.

If the response is not received within 2.5 seconds, a transmit error is generated by setting error bit Tx in the status word.

If the response is received in time, the checksum is checked. If the checksum is invalid, if time t1.5 has elapsed on receipt, or if a parity error has occurred, a receive error is then generated by setting error bit Rx in the status word.

On error-free receipt, the "Rx buffer not empty" bit is set in the status word.

The checksum bytes are not included when reading the receive data.

13 Process data

The module is parameterized via the PDI channel, data exchange with the higher-level controller depends on the parameter data way and is either via process data or via PDI.

The module has ten words of process data each in the input direction and output direction. These are made up of 3 bytes of frame data and a maximum of 17 bytes of user data.

Assignment of the ten process data words

Word	0		1		2		...	9	
Byte in the Motorola format	0	1	2	3	4	5	...	18	19
Byte in the Intel format	1	0	3	2	5	4	...	19	18
OUT	K/P	S	L	D	D	D	...	D	D
IN	K/P	S	L	D	D	D	...	D	D

K/P Command/parameter

S Control bits (OUT) or status bits (IN)

L Length: number of characters to be written (OUT) or to be read (IN)

D Data



The byte representation in Motorola format, also called Big Endian (high order byte at starting address), corresponds to INTERBUS standard representation. All byte representations in the data sheet have this format.

The byte representation in Intel format is also called Little Endian (low order byte at starting address).

The command is used to determine the function. The actually transmitted data depends on the command.

14 Process data word 0

14.1 Control word

15	14	13	12	11	10	9	8	7	6	5	4	3	2	1	0
0	Command			OUT parameter				Control bits							

Control bits

7	6	5	4	3	2	1	0
DTR	0	0	0	0	Reset transmit error	Reset receive error	0

DTR (if DTR control enabled)		
Code (bin)	Meaning	Protocol
0	DTR = logic 0	All
1	DTR = logic 1	



The DTR signal can only be controlled via the bit if you have parameterized interface type RS-232 and DTR control via process data in the parameter table.

Reset transmit error		
Code (bin)	Meaning	Protocol
0	No action	Modbus/RTU
1	Reset transmit error	

Reset receive error		
Code (bin)	Meaning	Protocol
0	No action	Modbus/RTU
1	Reset receive error	

Commands

Code (bin)	Code (hex)	Command
000	0	Read number of characters received (in the transparent and XON/XOFF protocol) and fill level of the receive buffer
001	1	Transmit characters
010	2	Store characters temporarily
011	3	OUT parameter = 0 _{hex} : Read characters
		OUT parameter = C _{hex} : Read firmware version
		OUT parameter = E _{hex} : Read counters
100	4	Reserved
101	5	Toggling command 1: Transmit characters
110	6	Toggling command 2: Store characters temporarily
111	7	Toggling command 3: Read characters

Command toggling

Command toggling is used to execute a command on a terminal again. In this way, a second command code is available for the same function.

This applies for the following commands:

- Transmit characters
- Store characters temporarily
- Read characters
- Read counters

Here, bit 14 is used for toggling. If, for example, you wish to transmit character strings in sequence, use command code 001_{bin} for the first transmission and then use 101_{bin} and 001_{bin} alternately.

14.2 Status word

15	14	13	12	11	10	9	8	7	6	5	4	3	2	1	0
St		Command			IN parameter			Status bits							

St Error bit

Reasons for an error bit set:

- Invalid parameter for the specified command
- Failure of the I/O voltage

Status bits

7	6	5	4	3	2	1	0
DSR	Transmit buffer not empty	Transmit buffer full	Receive buffer full	DCD	Transmit error	Receive error	Receive buffer not empty

DSR		
Code (bin)	Meaning	Protocol
0	DSR = logic 0	All
1	DSR = logic 1	

The DSR signal state is displayed, if you have parameterized interface type RS-232.

Transmit buffer not empty		
Code (bin)	Meaning	Protocol
0	Empty	All
1	Not empty, transmission in progress	

Transmit buffer full		
Code (bin)	Meaning	Protocol
0	Not full	All
1	Full	

Protocol	Meaning: transmit buffer full
Modbus/RTU	No more buffer space
Other	Space remaining in the transmit buffer ≤ 30 characters

Receive buffer full		
Code (bin)	Meaning	Protocol
0	Not full	All
1	Full	

Protocol	Meaning: receive buffer full
Transparent	Space remaining ≤ 15 characters
XON/XOFF	Space remaining ≤ 15 characters
Modbus/RTU	No more buffer space
End-to-end	No more buffer space

DCD		
Code (bin)	Meaning	Protocol
0	DCD = logic 0	All
1	DCD = logic 1	

The DCD signal state is displayed, if you have parameterized interface type RS-232.

Transmit error		
Code (bin)	Meaning	Protocol
0	No error	Modbus/RTU
1	Transmit error; 2.5 s timeout has elapsed with no response received	

Receive error		
Code (bin)	Meaning	Protocol
0	No error	Modbus/RTU
1	Receive error; telegram received with invalid checksum	

Receive buffer not empty		
Code (bin)	Meaning	Protocol
0	Empty	All
1	Not empty; characters to be read are available	

15 Commands

15.1 “Read number of characters received and fill level of the receive buffer” command

For the transparent and XON/XOFF protocol, the command result is the number of characters that have been received but not yet read.

The number is a 16-bit value and is mapped to word 1.

This command can be used to first reach a minimum number of characters before transmitting the "Read characters" command.

For all protocols, the fill level of the receive buffer is specified in byte 4 as the command result.

Process data assignment for the “Read number of characters received and fill level of the receive buffer” command

Word	0		1		2		...	9	
Byte	0	1	2	3	4	5	...	18	19
OUT	00 _{hex}	xx	xx	xx	xx	xx	...	xx	xx
IN	00 _{hex}	Status bits	Number of characters received		Fill level	xx	...	xx	xx

Fill level		
Byte 4	Protocol	
	Transparent, XON/XOFF	End-to-end, Modbus/RTU
	Number of kbytes free	Number of buffers free
00 _{hex}	4	3
01 _{hex}	< 3	2
02 _{hex}	< 2	1
03 _{hex}	< 1	0

15.2 “Transmit characters” command

The transmit data located in the process data is stored in the transmit memory. From there the data is transmitted directly via the interface.

A maximum of 17 characters can be entered.

Specify the number of characters to be transmitted in the third byte.

If there are characters in the intermediate buffer, these are transmitted first via the selected RS interface.

After the command has been executed successfully, the intermediate buffer is cleared.

Process data assignment for the “Transmit characters” command with 17 characters (Z1 - Z17)

Word	0		1		2		...	9	
Byte	0	1	2	3	4	5	...	18	19
OUT	10 _{hex}	xx	17 _{dez}	Z1	Z2	Z3	...	Z16	Z17
IN	10 _{hex}	Status bits	xx	xx	xx	xx	...	xx	xx

Reasons for an error bit set:

- Byte 2 (number of characters to be transmitted)
= 0 or > maximum user data length (17 characters)
- Interface type “Deactivated”
- Data way: data exchange via PDI

15.3 “Store characters temporarily” command

If more than 17 characters are to be transmitted, the transmit data located in the process data is stored in an intermediate buffer which can store up to 340 characters. No characters are transmitted. The “Transmit characters” command is used to transmit temporarily stored data. In this way, blocks of up to 340 characters can be transmitted without a break. They are divided over 20 telegrams with 17 characters each, for example.

Process data assignment for the “Store characters temporarily” command with 17 characters (Z1 - Z17)

Word	0		1		2		...	9	
Byte	0	1	2	3	4	5	...	18	19
OUT	20 _{hex}	xx	17 _{dez}	Z1	Z2	Z3	...	Z16	Z17
IN	20 _{hex}	Status bits	xx	xx	xx	xx	...	xx	xx

Reasons for an error bit set:

- Byte 2 (number of characters to be transmitted)
= 0 or > maximum user data length (17 characters)
- Not enough space in the intermediate buffer

15.4 "Read characters" command

A maximum of 17 characters can be read.

For block-oriented protocols (end-to-end, Modbus/RTU), the received telegram may be longer than the user data length. In order to indicate that there is more data to be retrieved from the telegram after reading, bit 7 is set in the third receive byte (byte 2).

Process data assignment for the "Read characters" command with 17 characters (Z1 - Z17)

Word	0		1		2		...	9	
Byte	0	1	2	3	4	5	...	18	19
OUT	30 _{hex}	xx	xx	xx	xx	xx	...	xx	xx
IN	30 _{hex}	Status bits	11 _{hex}	Z1	Z2	Z3	...	Z16	Z17

Bit 7 in the third input byte (byte 2)

Byte 2, bit 7	Effect	Protocol
0	The characters read are the last ones in the block received.	e.g., end-to-end
1	There are still more characters to be read from the block received.	e.g., end-to-end

Reasons for an error bit set:

- Interface type "Deactivated"
- Data way: data exchange via PDI

15.5 "Read counters" command

This command can be used to read several counters. The counters are used for interface diagnostics.

Process data assignment for the "Read counters" command

Word	0		1		2		3		4		5		6	
Byte	0	1	2	3	4	5	6	7	8	9	10	11	12	13
OUT	3E _{hex}	00 _{hex}	xx	xx	xx	xx	xx	xx	xx	xx	xx	xx	xx	xx
IN	3E _{hex}	Status bits	Number of valid characters received		Number of invalid characters received (parity, overrun or framing errors)		Number of characters transmitted		Reserved					

16 Parameter, diagnostics and information (PDI)

Parameter and diagnostic data as well as other information is transmitted as objects via the PDI channel of the Axioline F station.

The standard and application objects stored in the module are described in the following section.

The following applies to all tables below:

Please refer to the UM EN AXL F SYS INST for an explanation of the data types.

Abbreviation	Meaning
A	Number of elements
L	Length of the elements in bytes
R	Read
W	Write



Each visible string is terminated with a null terminator (00_{hex}). The length of a visible-string-type element is therefore at least one byte larger than the number of user data items.

If the number of user data items plus null terminator is smaller than the specified length of the element, the visible string will be populated with a null character (00_{hex}).



For detailed information on PDI objects, please refer to the UM EN AXL F SYS INST user manual.

17 Standard objects

17.1 Objects for identification (device rating plate)

Index (hex)	Object name	Data type	A	L	Rights	Meaning	Contents
Manufacturer							
0001	VendorName	Visible String	1	16	R	Vendor name	Phoenix Contact
0002	VendorID	Visible String	1	7	R	Vendor ID	00A045
0003	VendorText	Visible String	1	49	R	Vendor text	Components and systems for industrial automation
0012	VendorURL	Visible String	1	23	R	Vendor URL	www.phoenixcontact.com
Module - general							
0004	DeviceFamily	Visible String	1	20	R	Device family	I/O function module
0006	ProductFamily	Visible String	1	6	R	Product family	AXL F
000E	CommProfile	Visible String	1	4	R	Communication profile	633
000F	DeviceProfile	Visible String	1	5	R	Device profile	0010
0011	ProfileVersion	Record of Visible Strings	2	11; 20	R	Profile version	2011-12-07; Basis - Profil V2.0
0017	Language	Record of Visible Strings	2	6; 8	R	Language	en-us; English
003A	VersionCount	Array of UINT16	4	4 * 2	R	Version counter	e. g., 0007 0001 0001 0001 _{hex}
Module - special							
0005	Capabilities	Visible String	1	8	R	Capabilities	Energ_0
0007	ProductName	Visible String	1	16	R	Product name	AXL F RS UNI 1H
0008	SerialNo	Visible String	1	11	R	Serial number	e. g., 1234512345
0009	ProductText	Visible String	1	24	R	Product text	1 communication channel
000A	OrderNumber	Visible String	1	8	R	Order No.	2688666
000B	HardwareVersion	Record of Visible Strings	2	11; 3	R	Hardware version	e. g., 2011-02-04; 00
000C	FirmwareVersion	Record of Visible Strings	2	11; 6	R	Firmware version	e. g., 2010-06-21; V1.10
000D	PChVersion	Record of Visible Strings	2	11; 6	R	PDI version	2010-01-08; V1.00
0037	DeviceType	Octet string	1	8	R	Device type	00 00 08 14 00 00 00 C0 _{hex}
Use of the device							
0014	Location	Visible String	1	58	R/W	Location	Can be completed by the user.
0015	EquipmentIdent	Visible String	1	58	R/W	Equipment identifier	Can be completed by the user.
0016	ApplDeviceAddr	UINT16	1	2	R/W	Application device address	Can be completed by the user.

17.2 Miscellaneous standard objects

Index (hex)	Object name	Data type	A	L	Rights	Meaning/contents	
Object descriptions							
0038	ObjDescrReq	Record	2	3	R/W	Object description request	
0039	ObjDescr	Record	16	Max. 58	R	Object description	
Diagnostics objects							
0018	DiagState	Record	6	21	R	Diagnostic state	*
0019	ResetDiag	UINT8	1	1	W	Acknowledge diagnostic messages	*
Objects for process data management							
0025	PDIN	Octet string	1	20	R	Input process data	*
0026	PDOUT	Octet string	1	20	R	Output process data	*
003B	PDIN_Descr	Array of Records	6	24	R	Description of the IN process data	
003C	PDOUT_Descr	Array of Records	6	24	R	Description of the output process data	

The objects identified with * in the last column are described in more detail in the following sections.

The description of the other objects is to be found in the user manual UM EN AXL F SYS INST.

The objects 003B_{hex} and 003C_{hex} are only applicable to tools.

17.3 Diagnostics objects

17.3.1 Diagnostics state (0018_{hex}: DiagState)

This object is used for a structured message of an error.

0018 _{hex} : Diagnostics state (read)				
Subindex	Data type	Length in bytes	Meaning	Contents
0	Record	21	Diagnostic state	Complete diagnostics information
1	UINT16	2	Error number	0 ... 65535 _{dec}
2	UINT8	1	Priority	00 _{hex} No error
				01 _{hex} Error
				02 _{hex} Warning
				81 _{hex} Error removed
				82 _{hex} Warning eliminated
3	UINT8	1	Channel/group/module	00 _{hex} No error
				01 _{hex} Channel 1
				FF _{hex} Entire device
4	UINT16	2	Error code	See table below
5	UINT8	1	More follows	00 _{hex}
6	Visible String	14	Text	See table below



The message with priority 81_{hex} or 82_{hex} is a one-off, internal message to the bus coupler. The bus coupler transfers this error message to the error mechanisms of the higher-level system.

Error and status of the local diagnostics and status indicators

Subindex	2	3	4	6	LED			
Error	Priority	Channel/ group/ module	Error code	Text	D	UI	E1	E2
	hex	hex	hex					
No error	00	00	0000	Status OK	●	●	○	○
Receive buffer full	02	01	7610	Rx-Buf full	●	●	○	●
Transmit buffer full	02	01	7611	Tx-Buf full	●	●	○	●
Faulty supply voltage	01	FF	5160	Supply fail	⚡	○	●	●
Device error	01	FF	6301	CS FLASH	⚡	●	○	●

Key:

- Off
- On
- Green on
- ⚡ Green/yellow flashing



After all errors have been eliminated, it is automatically reset.

17.3.2 Acknowledge diagnostic messages (0019_{hex}: ResetDiag)

You can delete the diagnostics memory and acknowledge the diagnostic messages with this object.

0019 _{hex} : Acknowledge diagnostic messages (read, write)				
Subindex	Data type	Length in bytes	Contents	
			Code (hex)	Meaning
0	UINT8	1	00	Permit all diagnostic messages
			02	Delete and acknowledge all diagnostic messages that are still pending
			06	Delete and acknowledge all diagnostic messages and do not permit new diagnostic messages
			Other	Reserved

17.4 Objects for process data management

17.4.1 IN process data (0025_{hex}: PDIN)

You can read the IN process data of the module with this object.

The structure corresponds to the representation in the "Process data" section.

0025 _{hex} : IN process data (read)			
Subindex	Data type	Length in bytes	Meaning
0	Octet string	20	Input process data

17.4.2 OUT process data (0026_{hex}: PDOUT)

You can read the OUT process data of the module with this object.

The structure corresponds to the representation in the "Process data" section.

0026 _{hex} : OUT process data (read)			
Subindex	Data type	Length in bytes	Meaning
0	Octet string	20	Output process data

18 Application objects

Index (hex)	Object name	Rights	Contents
0080	ParaTable	R/W	Parameter table
0081	SerialData	R/W	Serial data
0095	EventCounter	R	Event counter

18.1 Parameter table (0080_{hex}: ParaTable)

Parameterize the module using this object.

In the case of valid parameters, the parameterization is stored in the module permanently.

After resetting, the module works with the last permanently stored data. Upon delivery, the module works with the default data (default settings).

0080 _{hex} : Parameter table (read, write)		
Subindex	Data type	Length in bytes
0	Octet string	16

Byte	Meaning	Default value
0	Type, protocol	30 _{hex}
1	Baud rate, data width	72 _{hex}
2	1st delimiter	0D _{hex}
3	2nd delimiter	0A _{hex}
4	Error pattern	24 _{hex}
5 ... 7	Uni1 ... Uni3	00 00 00 _{hex}
8	Reserved	00 _{hex}
9	Data way	00 _{hex}
10	Tv	00 _{hex}
11	Tn	00 _{hex}
12 ... 15	Reserved	00 00 00 00 _{hex}

Element value range



The options in bold are default settings.

Byte 0 (T/P: interface type/protocol)

7	6	5	4	3	2	1	0
res.	DTR	Interface type	Protocol				

DTR: DTR control	
Code (bin)	Meaning
0	Automatic
1	Can be controlled via process data

DTR control is only significant for interface type RS-232. For automatic control, the following applies in the transparent protocol and in the XON/XOFF protocol:

- DTR = logic 0 There are a maximum of 15 characters free in the receive buffer.
- DTR = logic 1 There are more than 15 characters free in the receive buffer.

For control via process data, the DTR signal can be controlled directly with bit 7 (DTR).

Interface type	
Code (bin)	Meaning
00	RS-232
01	RS-485
10	RS-422
11	Deactivated



Select an RS-xxx interface type. With the "Deactivated" default setting, no data is transmitted or received. When using the default setting, an error message is generated and the error bit is set.

Protocol	
Code (hex)	Meaning
0	Transparent
1	End-to-end
2	XON/XOFF
3	Modbus/RTU
Other	Reserved

Byte 1 (baud rate/data width)

Baud rate	
Code (hex)	Wert (baud)
0	110
1	300
2	600
3	1200
4	1800
5	2400
6	4800
7	9600
8	15625
9	19200
A	38400
B	57600
C	115200
D	230400
E	250000
F	Direct (Uni1 ... 3)



The specified baud rates of 110 baud to 250000 baud are adequate for most applications. However, you can freely choose the baud rate by direct programming. For this, use the 0F_{hex} baud rate code.

Data width			
Code (hex)	Meaning		
	Data bits	Parity	Stop bits
0	7	Even	1
1	7	Odd	1
2	8	Even	1
3	8	Odd	1
4	8	Without	1
5	7	Without	1
6	7	Even	2
7	7	Odd	2
8	8	Even	2
9	8	Odd	2
A	8	Without	2
B	7	Without	2
C	8	Constantly at 0	1
D	8	Constantly at 1	1
E	6	without	1
F	Directly (Uni1)		



The specified combinations of data width, parity and stop bits are adequate for most applications. However, you can freely choose the combination by direct programming. For this, use the 0F_{hex} data width code.

Byte 2 and 3 (1st del, 2nd del: 1st and 2nd delimiters)

The 1st delimiter and 2nd delimiter contain the end characters for the end-to-end and dual buffer protocols. When selecting the end-to-end protocol, the two delimiters can be adjusted. Default settings:

Delimiter	Default value	ASCII character
1st del	0D _{hex}	CR = carriage return
2nd del	0A _{hex}	LF = line feed

Byte 4 (ErrP: error pattern)

The error pattern contains the character that is written to the FIFO if a character was received with errors (e.g., in the event of a parity error).

The error pattern is used for the following protocols:

- Transparent
- End-to-end
- XON/XOFF

Error pattern	
Code (hex)	Meaning
24	\$
xx	Any character
00	If a character is received with an error, no error pattern is stored.
FF	The invalid character is stored instead of the error pattern.

Byte 5 ... 7 (Uni1 ... Uni3: universal byte 1 ... 3)

These bytes can be used as universal bytes for direct specification of the baud rate or the data width.

Byte 5				Byte 6			Byte 7						
7	6	5	4	3	2	1	0	7	...	0	7	...	0
Data width				Baud rate									

Direct specification of the data width

If the provided combinations of data width, parity and stop bits are inadequate, they can be directly specified. Use the Uni1 byte. Bit 1 and bit 0 are reserved.

7	6	5	4	3	2	1	0
Parity		Enable parity	Stop bits	Data bits		res.	res.

Parity	
Code (bin)	Meaning
00	Odd
01	Even
10	Constantly at 1
11	Constantly at 0

Enable parity	
Code (bin)	Meaning
0	Disable
1	Enable

Stop bits	
Code (bin)	Meaning
0	1 stop bit
1	2 stop bits

Data bits	
Code (bin)	Meaning
00	5 bits
01	6 bits
10	7 bits
11	8 bits

Direct specification of baud rate

If the provided baud rates do not correspond to the desired baud rate, the baud rate can be directly specified. For this, write the desired baud rate on the Uni1 to Uni3 fields in the form of a numeric value. Transfer is right-aligned. However, only the 2 lower bits of Uni1 are permitted.

The maximum value is 18 bits. The maximum value = 3FFFF_{hex} which corresponds to 262143 baud.

Example for direct specification of the baud rate:

- Baud rate: 100000 baud
- 100000_{dez} = 01 86 A0_{hex}

Byte	Meaning	Assignment
0	Type, protocol	xx _{hex}
1	Baud rate, data width	Fx _{hex}
2	1st delimiter	00 _{hex}
3	2nd delimiter	00 _{hex}
4	Error pattern	xx _{hex}
5 ... 7	Uni1 ... Uni3	01 86 A0 _{hex}
8	Reserved	00 _{hex}
9	Data way	00 _{hex}
10	Tv	xx _{hex}
11	Tn	xx _{hex}
12 ... 15	Reserved	00 00 00 00 _{hex}

Byte 9 (data way)

Here you can control the path used to exchange data with the selected interface.

Data way	
Code (hex)	Meaning
00 _{hex}	Data exchange via process data
01 _{hex}	Data exchange via PDI

Data exchange via process data	340 bytes per buffer A maximum of 17 characters can be transmitted together using the "Transmit characters" command. If you want to transmit more characters, use the "Store characters temporarily" command.
Data exchange via PDI	245 bytes per buffer

Byte 10 and 11 (Tv, Tn: lead time, lag time)

These two times are used for the RS-232 protocol

- Tv Lead time
- Tn Lag time

The times are specified with a resolution of 1 ms. This allows for waiting times of 1 ms ... 255 ms.

When transmitting data via RS-232 the RTS signal is set. If Tv does not equal 0, transmission only starts after this time has elapsed. After all the data is sent and Tn does not equal 0, the RTS signal is only set to LOW after this time has elapsed.

18.2 Serial data (0081_{hex}: SerialData)

If you have parameterized data exchange via PDI in the “Data way” parameter in the parameter table, this object can be used to read and write the serial data.

0081 _{hex} : SerialData (read, write)			
Subindex	Data type	Length in bytes	Contents
0	Var	0 ... 245	Serial data

On write access, the user data of this service is transmitted directly via the interface.

On read access, the user data corresponds to the received characters.

The maximum user data length is 245 bytes.

In the case of the Modbus/RTU protocol, on write access after transmitting the user data, two bytes are appended for a checksum determined by the module.

On read access, the checksum is no longer present when the user data is received.

Error	Error class (hex)	Error code (hex)	Additional code (hex)
“Data way” parameter = 00 _{hex} (data exchange via process data)	8	0	0022
“Interface” parameter = 3 _{hex} (deactivated)	8	0	0122
On write access, there is not enough space in the transmit memory	8	0	0222
On read/write access, the previous read/write access has not yet been completed	8	0	0322
On write access, the length is equal to 0 or greater than 245	6	5	0000

18.3 Event counter (0095_{hex}: EventCounter)

You can read multiple counters which are used for interface diagnostics with this object.

0095 _{hex} : EventCounter (read)		
Subindex	Data type	Length in bytes
0	Octet string	12

Word	Meaning
1	Number of valid characters received
2	Number of invalid characters received (parity, overrun or framing errors)
3	Number of characters transmitted
4 ... 6	Reserved

19 Device descriptions

The device is described in the device description files. The device descriptions for controllers from Phoenix Contact are included in PC Worx and PLCnext Engineer, as well as in the corresponding service packs. The device description files for other systems are available for download at phoenixcontact.net/products in the download area of the bus coupler installed.